



GLOBAL PLATFORM MANUAL MONITOR STYLE 3430 INSTALLATION, OPERATING AND MAINTENANCE INSTRUCTIONS

The following is intended to provide the basic instructions for installation, operating and maintenance of the Global Platform Manual Monitor. Read and understand these operating instructions before use.

PRODUCT RATINGS:

Maximum Flow:	1000 gpm (3800 lpm)
Maximum Pressure:	200 psi (1400 kpa)

PRODUCT WARNINGS:

The reaction force when flowing at the maximum pressure and flow listed above is 750 pounds. The center of the waterway is 10 ³/₁₆ inches from the bottom of the inlet flange. Ensure these values plus an appropriate safety factor are used to determine a proper support structure.

- ⚠ WARNING:** INSUFFICIENT STRUCTURAL SUPPORT CAN LEAD TO FAILURE, WHICH HAS POTENTIAL TO CAUSE AN INJURY. THEREFORE, ADDITIONAL STRUCTURAL SUPPORT AT THE INLET FLANGE MAY BE REQUIRED. NO SUPPORT STRUCTURE IS TO BE ADDED DIRECTLY TO THE MONITOR.
(Contact Akron Brass Customer Service for assistance.)
- ⚠ WARNING:** Charge the unit slowly. Rapid charging may cause a pressure surge which has the potential to cause an injury or damage the monitor.
- ⚠ WARNING:** Aim the unit in a safe direction before pumping water through it.
- ⚠ WARNING:** DO NOT exceed the maximum pressure or flow ratings of the monitor. Exceeding these ratings has the potential to cause an injury or damage the monitor.
- ⚠ WARNING:** DO NOT install shutoffs on the outlet of the monitor. Shutoffs increase the potential for pressure surges due to water hammer, which have the potential to cause injury or damage the monitor.
- ⚠ WARNING:** Drain the monitor after use to prevent “freeze damage”.
- ⚠ WARNING:** Ensure the thread on the nozzle swivel matches the thread on the monitor outlet. Do not over tighten the nozzle onto the unit.

MONITOR ATTACHMENT:

The monitor is to be mounted on the waterway with eight 5/8 inch bolts and nuts of grade five minimum and suitable washers when mounting to a DIN 80 flange. When mounting to a three inch flange, only four bolts, nuts and washers are required.

OPERATING INSTRUCTIONS:

The tiller bar and the upper and lower brake knobs are used to control the monitor. To change the horizontal monitor position toward the "RIGHT" or "LEFT", get a firm grip on the tiller bar handle and turn the lower brake knob counterclockwise until the unit can be easily rotated. Turn the same knob clockwise to lock the unit in the desired horizontal position. To change the vertical monitor position upward or downward, get a firm grip on the tiller bar handle and turn the upper brake knob counterclockwise until the unit can be easily elevated or lowered. Turn the same knob clockwise to lock the unit in the desired elevation position.

Figure 1

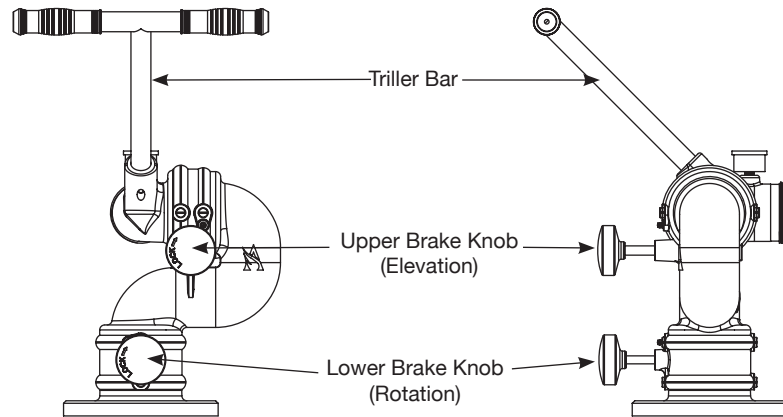

CAUTIONS:

Your monitor and nozzle should be inspected prior to and after each use to ensure it is in good operating condition. Periodically, an unanticipated incident occurs where the unit is misused in a manner that is inconsistent with standard operating practices. A partial list of potential misuses includes:

- Operating above maximum rated pressure or flow.
- Not draining and allowing water to freeze in the unit.
- Prolonged exposure to temperatures above 140 degrees F, or below -40 degrees F.
- Operating in a corrosive environment.
- Other misuse that may be unique to your specific environment.

Also, there are many "tell tale" signs that indicate repair is in order, such as:

- A brake knob that is inoperable or difficult to operate.
- Excessive wear.
- Poor discharge performance.
- Water leaks.

If any of the above situations are encountered, the monitor should be taken out of service, repaired and tested by a qualified technician before placing it back in service.

MAINTENANCE INSTRUCTIONS:

- Periodically lubricate the grease fittings with Lubriplate Low-Temp or equivalent. Inject the lubricant until it becomes visible from the bleeder holes in the center of the swivel plugs.
- Periodically clean grit and dirt from around exterior moving parts.
- Periodically operate all functions of the monitor through its full travel.
- The brake mechanism on the horizontal and vertical travel may require periodic maintenance. To check the adjustment, rotate the brake knob counterclockwise until it stops. Turning the brake knob clockwise 1 to 1 1/2 turns should lock the monitor. If the monitor does not lock, remove the lock mechanism, inspect for wear and replace components as necessary.
- Replace the identification tag if it is worn or damaged.



PHONE: 330.264.5678 or 800.228.1161 | FAX: 330.264.2944 or 800.531.7335 | www.akronbrass.com

REVISED: 10/10

WARRANTY AND DISCLAIMER: We warrant Akron Brass products for a period of five (5) years after purchase against defects in materials or workmanship. Akron Brass will repair or replace product which fails to satisfy this warranty. Repair or replacement shall be at the discretion of Akron Brass. Products must be promptly returned to Akron Brass for warranty service.

We will not be responsible for: wear and tear; any improper installation, use, maintenance or storage; negligence of the owner or user; repair or modification after delivery; damage; failure to follow our instructions or recommendations; or anything else beyond our control. WE MAKE NO WARRANTIES, EXPRESS OR IMPLIED, OTHER THAN THOSE INCLUDED IN THIS WARRANTY STATEMENT, AND WE DISCLAIM ANY IMPLIED WARRANTY OF MERCHANTABILITY OR FITNESS FOR ANY PARTICULAR PURPOSE. Further, we will not be responsible for any consequential, incidental or indirect damages (including, but not limited to, any loss of profits) from any cause whatsoever. No person has authority to change this warranty.

© Premier Farnell Corporation. 2010 All rights reserved. No portion of this can be reproduced without the express written consent of Premier Farnell Corporation.

A Premier Farnell Company