

TECHNICAL SERVICE PARTS

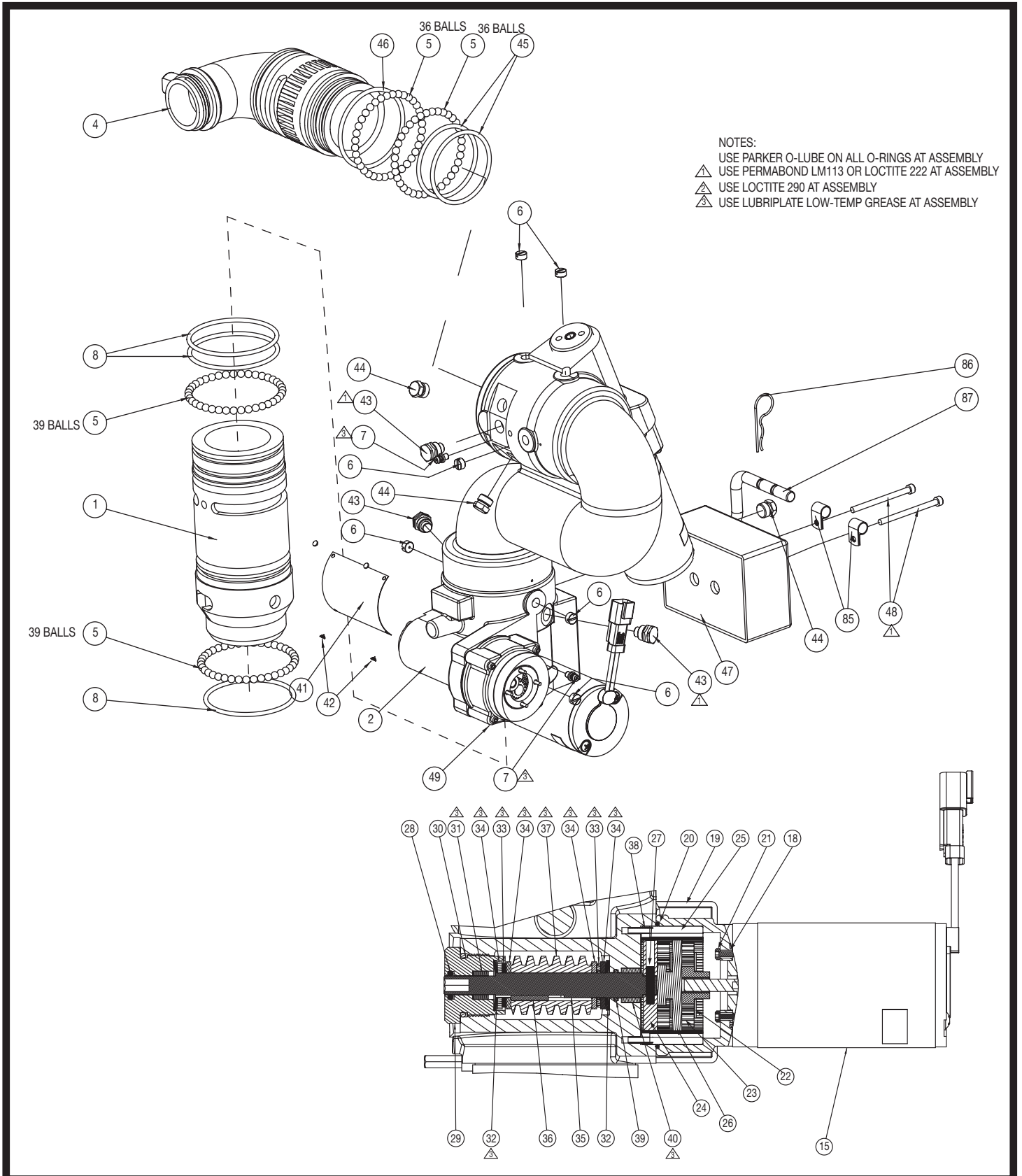



**STYLE 3462
FORESTRY BUMPER MONITOR
TECHNICAL SERVICE PARTS LIST**

| ITEM NO. | DESCRIPTION | PART NUMBER | QTY |
|----------|-----------------------------|-----------------------|-----|
| 1 | 2" Base | 117898 | 1 |
| 2 | Inlet Elbow | 122371 | 1 |
| 4 | Outlet 1-1/2" Elbow | 122351 | 1 |
| 5* | Ball Bearing | * | 150 |
| 6 | Swivel Plug | 742023 | 7 |
| 7 | Grease Fitting | 713191 | 2 |
| 8 | O-Ring | 757065 | 3 |
| 15 | Motor 12v/24v | 34620001/ 34620002 | 2 |
| 18 | O-Ring | 757056 | 2 |
| 19 | Housing Gearbox | 109320 | 2 |
| 20 | O-Ring | 757312 | 2 |
| 21 | Socket Head Cap Screw | 765052 | 8 |
| 22 | Rivet | 754052 | 16 |
| 23 | Spur Gear | 718136 | 16 |
| 24 | Carrier | 707476 | 2 |
| 25 | Gear Internal Elevation | 718164 | 2 |
| 26 | Plate Carrier | 742120 | 2 |
| 27 | Pin Groove | 741056 | 2 |
| 28 | O-Ring | 757295 | 2 |
| 29 | Cap Bearing Elevation | 116465 | 2 |
| 30 | O-Ring | 757329 | 2 |
| 31 | Bearing | 704393 | 2 |
| 32 | Spring | 769276 | 4 |
| 33 | Bearing Thrust Roller | 703453 | 4 |
| 34 | Thrust Washer | 784121 | 8 |
| 35 | Shaft | 769697 | 2 |
| 36 | Key | 727044 | 2 |
| 37 | Worm Gear | 718273 | 2 |
| 38 | Roll Pin | 744288 | 4 |
| 39 | O-Ring | 757041 | 2 |
| 40 | Bearing Roller Needle | 704395 | 2 |
| 41 | ID Plate | 745217 | 1 |
| 42 | Nail Grip | 736045 | 4 |
| 43 | Stop | 769498 | 3 |
| 44 | Plug | 744337 | 3 |
| 45 | O-Ring | 757205 | 2 |
| 46 | O-Ring | 757126 | 1 |
| 47 | Forestry Control | 60400003 | 1 |
| 48 | Socket Head Cap Screw | 763078 | 2 |
| 49 | Socket Head Cap Screw | 767132 | 8 |
| 79 | Quick Disconnect (optional) | 3463-0001 | 1 |
| 85 | Cable Clamp | 707189 | 2 |
| 86 | Cotter Pin | 744339 | 1 |
| 87 | Override Handle | 721291 | 1 |

* Packet of 50 Ball Bearings - P/N 109041



PHONE: 330.264.5678 or 800.228.1161 | FAX: 330.264.2944 or 800.531.7335 | www.akronbrass.com

REVISED: 09/10

WARRANTY AND DISCLAIMER: We warrant Akron Brass products for a period of five (5) years after purchase against defects in materials or workmanship. Akron Brass will repair or replace product which fails to satisfy this warranty. Repair or replacement shall be at the discretion of Akron Brass. Products must be promptly returned to Akron Brass for warranty service.

We will not be responsible for: wear and tear; any improper installation, use, maintenance or storage; negligence of the owner or user; repair or modification after delivery; damage; failure to follow our instructions or recommendations; or anything else beyond our control. WE MAKE NO WARRANTIES, EXPRESS OR IMPLIED, OTHER THAN THOSE INCLUDED IN THIS WARRANTY STATEMENT, AND WE DISCLAIM ANY IMPLIED WARRANTY OF MERCHANTABILITY OR FITNESS FOR ANY PARTICULAR PURPOSE. Further, we will not be responsible for any consequential, incidental or indirect damages (including, but not limited to, any loss of profits) from any cause whatsoever. No person has authority to change this warranty.

© Premier Farnell Corporation. 2010 All rights reserved. No portion of this can be reproduced without the express written consent of Premier Farnell Corporation.

A Premier Farnell Company