

TECHNICAL SERVICE PARTS LIST

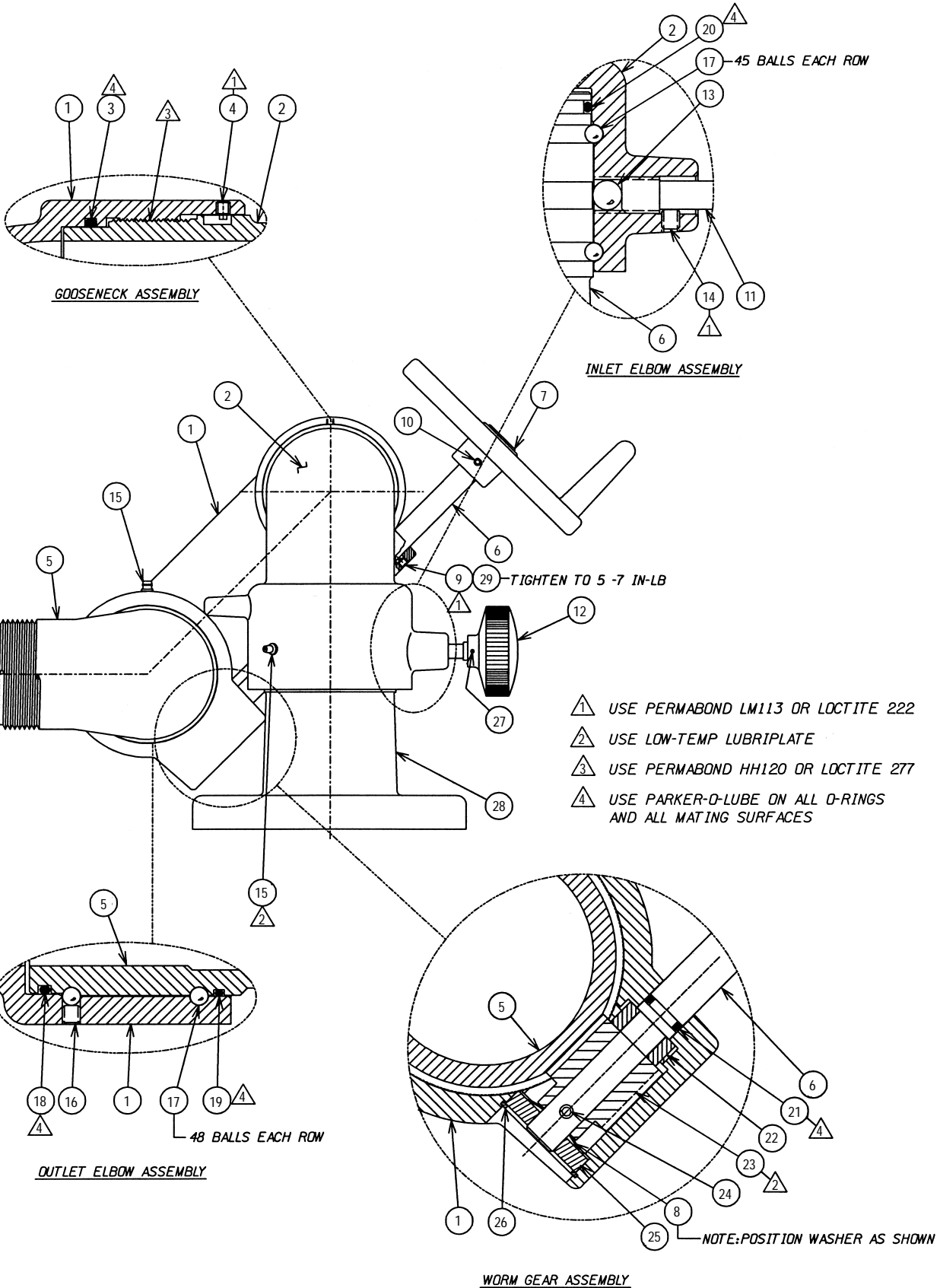



STYLE 3525
Brass Aries™ Monitor
TECHNICAL SERVICE PARTS LIST

ITEM NO.	DESCRIPTION	PART NUMBER	QUANTITY
1	Gooseneck	107750	1
2	Inlet Elbow	109843	1
3	O-Ring 3 5/8" x 3 3/8"	7-57-081	1
4	Socket HD Capscrew #10	7-67-088	1
5	Outlet Elbow	109842	1
6	Drive Shaft	7-69-558	1
7	Handwheel	107751	1
8	Spring Washer	7-68-199	1
9	Nylon Ball 3/16"	7-04-031	1
10	Roll Pin	7-44-060	1
11	Brake Shaft	7-70-219	1
12	Brake Handle Knob	109189	1
13	Brake Ball	7-03-211	1
14	Socket Set Screw	7-65-002	1
15	Grease Fittings	7-13-191	2
16	Swivel Plug	7-42-023	4
17	Ball Bearings	*	186
18	O-Ring 3 3/4" x 3 1/2"	7-57-036	1
19	O-Ring 3 11/16" x 3 1/2"	7-57-327	1
20	O-Ring 3 1/2" x 3 1/4"	7-57-035	1
21	O-Ring 5/8" x 7/16"	7-57-022	1
22	Spacer	7-69-557	1
23	Worm Gear	106611	1
24	Roll Pin	7-44-068	1
25	Bearing	7-04-508	1
26	Retaining Ring	7-58-221	1
27	Roll Pin	7-44-066	1
28	3" 150# Flange	117882	1
28	4" 150# Flange	117881	1
29	Socket HD Set Screw	7-65-008	1

* Packet of 50 Ball Bearings – P/N 109041



ISO 9001 REGISTERED COMPANY

PHONE: 330.264.5678 or 800.228.1161 | FAX: 330.264.2944 or 800.531.7335 | www.akronbrass.com
Available in Canada through AKRON MANUFACTURING COMPANY
PHONE: 519.773.8431 | FAX: 519.773.3794

AB-689 (REV. 05/01)

WARRANTY AND DISCLAIMER: We warrant Akron Brass products for a period of five (5) years after purchase against defects in materials or workmanship. Akron Brass will repair or replace product which fails to satisfy this warranty. Repair or replacement shall be at the discretion of Akron Brass. Products must be promptly returned to Akron Brass for warranty service. We will not be responsible for: wear and tear; any improper installation, use, maintenance or storage; negligence of the owner or user; repair or modification after delivery; damage; failure to follow our instructions or recommendations; or anything else beyond our control. WE MAKE NO WARRANTIES, EXPRESS OR IMPLIED, OTHER THAN THOSE INCLUDED IN THIS WARRANTY STATEMENT, AND WE DISCLAIM ANY IMPLIED WARRANTY OF MERCHANTABILITY OR FITNESS FOR ANY PARTICULAR PURPOSE. Further, we will not be responsible for any consequential, incidental or indirect damages (including, but not limited to, any loss of profits) from any cause whatsoever. No person has authority to change this warranty.

© Premier Farnell Corporation. 2000 All rights reserved. No portion of this can be reproduced without the express written consent of Premier Farnell Corporation.

A Premier Farnell Company