

TECHNICAL SERVICE PARTS

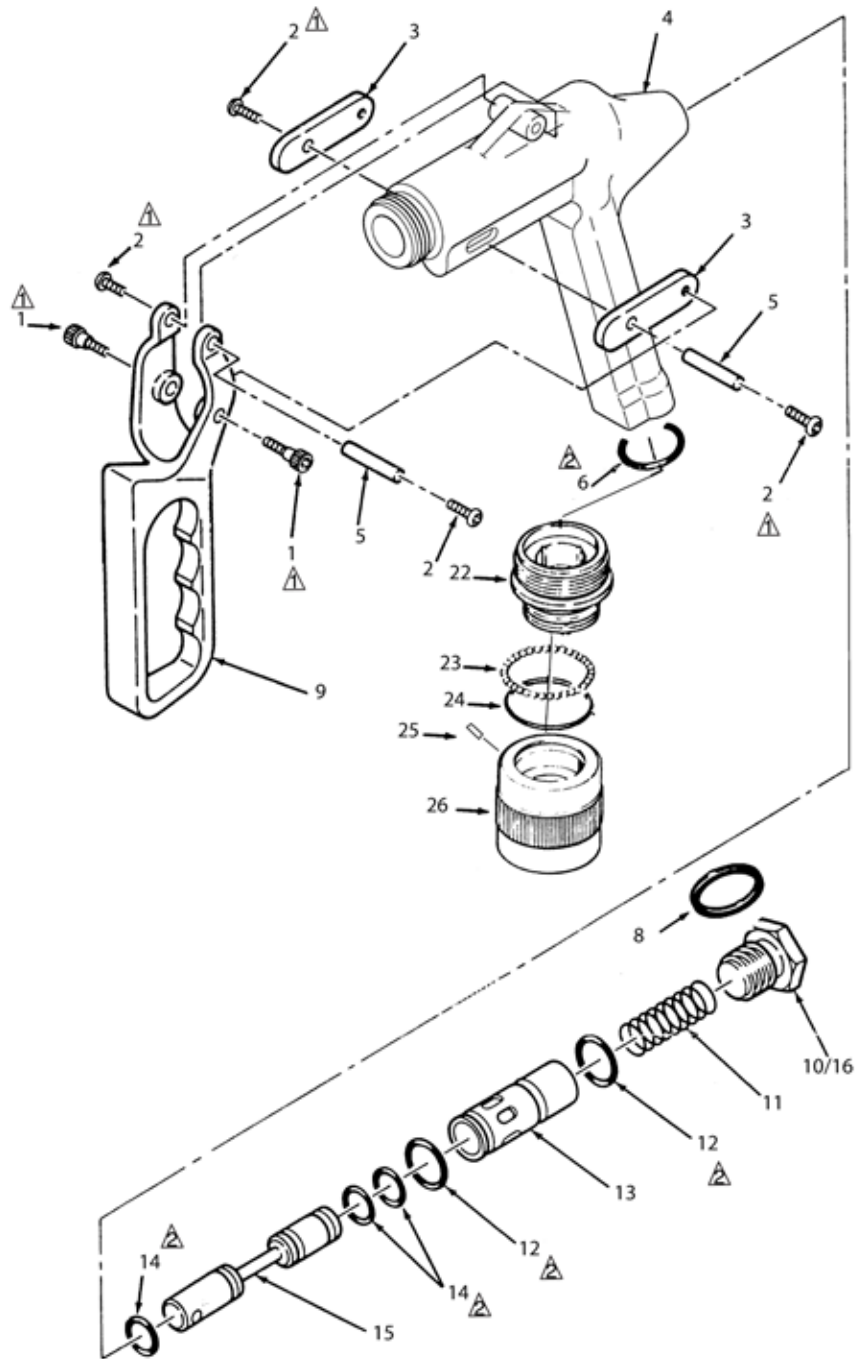

ASSEMBLY NOTES

- △ Use Loctite 222 or Permabond 113
- Use Parker O-Ring Lubricant or equivalent petroleum base lubricant



**STYLE 753
HIGH PRESSURE TRIGGER SHUTOFF
TECHNICAL SERVICE PARTS LIST**

ITEM NO.	DESCRIPTION	PART NUMBER	QUANTITY
1	Shoulder Screw	7-65-145	2
2	Button Head Screw	7-63-061	4
3	Link	101858	2
4	Shutoff Body	121066	1
4	Shutoff Body (Ultra High Pressure)	121053	1
5	Pin	109086	2
6	O-Ring	7-57-293	1
8	Swivel Gasket	7-17-047	1
9	Trigger	115419	1
10	Spring Holder	101857	1
11	Spring	7-69-383	1
11	Spring (Ultra High Pressure)	7-69-827	1
12	O-Ring	7-57-274	2
13	Sleeve	101859	1
14	O-Ring	7-57-275	3
15	Spool	121074	1
16	ID Label (not shown)	7-29-312	1
17	Rear Bumper (not shown)	7-04-377	1
18	Rear Bumper Screws (not shown)	7-65-028	2
19	Lock Open Latch (not shown)	107713	1
20	Screw for Item 19 (not shown)	7-65-197	2
21	Spring Washer for Item 19 (not shown)	7-68-276	1
22	Adapter	116247	1
23	Ball Bearings	7-04-018	23
24	O-Ring	7-57-064	1
25	Screw	7-65-134	1
26**	Swivel* BSP	116249	1

* For other threads order by description and thread size (ODM and TPI) or by Akron Thread Code.
 ** Be sure to order correct swivel. Older models use Piston Ring Assemblies. Current models use Ball Bearing Swivels.



PHONE: 330.264.5678 or 800.228.1161 | FAX: 330.264.2944 or 800.531.7335 | www.akronbrass.com

REVISED: 4/08

WARRANTY AND DISCLAIMER: We warrant Akron Brass products for a period of five (5) years after purchase against defects in materials or workmanship. Akron Brass will repair or replace product which fails to satisfy this warranty. Repair or replacement shall be at the discretion of Akron Brass. Products must be promptly returned to Akron Brass for warranty service.

We will not be responsible for: wear and tear; any improper installation, use, maintenance or storage; negligence of the owner or user; repair or modification after delivery; damage; failure to follow our instructions or recommendations; or anything else beyond our control. WE MAKE NO WARRANTIES, EXPRESS OR IMPLIED, OTHER THAN THOSE INCLUDED IN THIS WARRANTY STATEMENT, AND WE DISCLAIM ANY IMPLIED WARRANTY OF MERCHANTABILITY OR FITNESS FOR ANY PARTICULAR PURPOSE. Further, we will not be responsible for any consequential, incidental or indirect damages (including, but not limited to, any loss of profits) from any cause whatsoever. No person has authority to change this warranty.

© Premier Farnell Corporation. 2000 All rights reserved. No portion of this can be reproduced without the express written consent of Premier Farnell Corporation.

A Premier Farnell Company